

CHIR 204 Radiographic Physics and Protection**Midterm – Radiation Physics****Friday 12 September, 2003****DO NOT TURN OVER THIS PAGE
UNTIL INSTRUCTED TO DO SO**

Meanwhile, fill in your name and student ID above and on the separate multiple choice answer sheet, and read the instructions below.

Instructions

- **Make sure your name and ID are filled in above, and on the separate multiple choice answer sheet.**
- Part A consists of 10 multiple choice questions and is worth a total of 20 marks. Indicate your answers on the separate answer sheet provided.
- Part B consists of 6 questions worth a total of 40 marks. Answer ALL questions in the spaces provided.
- Use the backs of the exam pages for working or extra space if necessary.
- Time allotted: 60 minutes.

Part A: Multiple Choice

Answer these questions on the separate sheet provided.

Question 1

Two electrons, each with 100 keV of kinetic energy, pass close to a tungsten nucleus and produce x-ray photons via bremsstrahlung. The first electron passes close to the nucleus and emits a photon of energy E_1 , the second passes by at a greater distance from the nucleus and produces a photon of energy E_2 . The photon energies satisfy:

- A. $E_1 < E_2 < 100 \text{ keV}$ C. $E_1 = E_2 < 100 \text{ keV}$ E. $100 \text{ keV} < E_2 < E_1$
B. $E_2 < E_1 < 100 \text{ keV}$ D. $100 \text{ keV} < E_1 < E_2$

Question 2

List the following types of voltage supply in order from highest to lowest ripple:

- (1) three-phase, six pulse (3) three-phase, twelve pulse
(2) high-frequency (4) single-phase, fully-rectified

- A. 1, 2, 3, 4 B. 4, 3, 1, 2 C. 4, 1, 3, 2 D. 1, 3, 4, 2 E. 2, 3, 4, 1

Question 3

An x-ray source produces an exposure rate of 4 mR/hr at a distance of 2 metres. What is the exposure rate at 1 metre?

- A. 1 mR/hr B. 2 mR/hr C. 4 mR/hr D. 8 mR/hr E. 16 mR/hr

Question 4

Choose a pair of words to complete the following sentence correctly. High energy x-rays suffer _____ photoelectric absorption and _____ Compton scattering compared to low energy x-rays.

- A. more, more B. less, more C. more, less D. less, less E. equal, equal

Question 5

The intensity of x-rays increases from the anode side to the cathode side of the beam from an x-ray machine because of

- A. the heel effect. C. blooming. E. the inverse square law.
B. off-focus radiation. D. the line principle.

Question 6

An x-ray exposure is taken with settings of 0.5 sec, 100 kVp and 300 mA. If the high voltage across the x-ray tube is supplied by a high-frequency circuit, the energy deposited in the anode during the exposure is approximately

- A. 15 000 J. B. 21 000 J. C. 30 000 J. D. 60 000 J. E. 150 000 J.

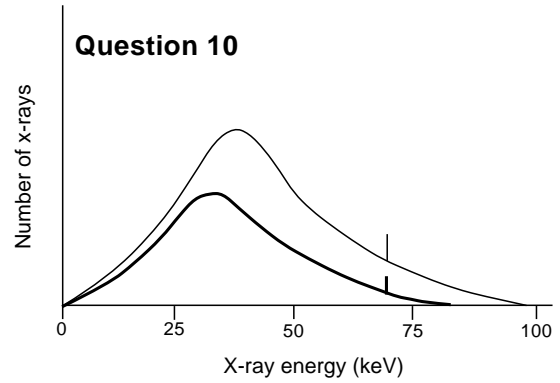
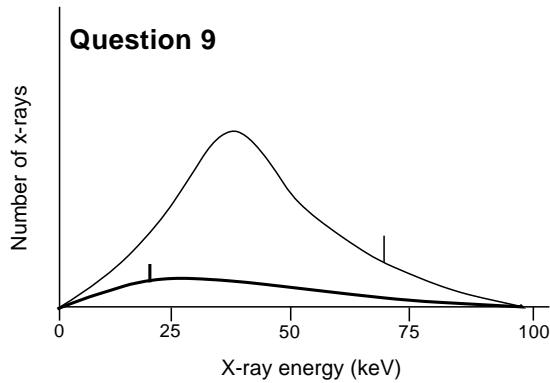
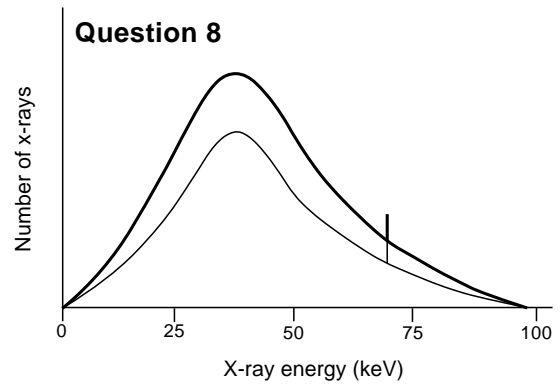
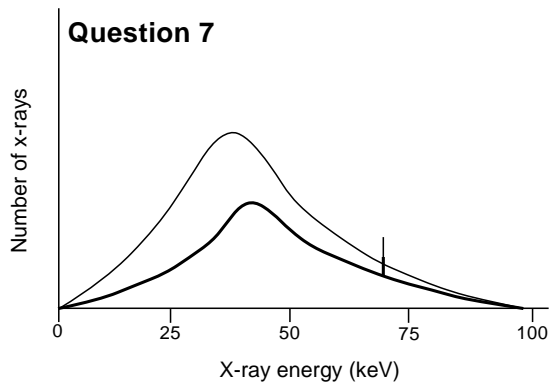

Questions 7–10 refer to the four panels above. In each panel, the lighter curve shows the spectrum produced by an x-ray machine during a certain exposure. Indicate the modification that would produce the spectrum represented by the darker curve in each panel.

Question 7

- | | | |
|-----------------|------------------------|--------------------------|
| A. increase kVp | C. increase mA | E. change anode material |
| B. decrease kVp | D. increase filtration | |

Question 8

- | | | |
|-----------------|------------------------|--------------------------|
| A. increase kVp | C. increase mA | E. change anode material |
| B. decrease kVp | D. increase filtration | |

Question 9

- | | | |
|-----------------|------------------------|--------------------------|
| A. increase kVp | C. increase mA | E. change anode material |
| B. decrease kVp | D. increase filtration | |

Question 10

- | | | |
|-----------------|------------------------|--------------------------|
| A. increase kVp | C. increase mA | E. change anode material |
| B. decrease kVp | D. increase filtration | |

End of Part A - Part B begins overleaf

Part B - Short Answer Questions

Answer these questions in the spaces provided. You may use the backs of the exam pages for working or extra space if necessary.

Question 1

Draw a diagram of an x-ray tube, and label the following components: anode, bearings, cathode, filament, focussing cup, housing, rotor, shaft, stator. Indicate the position of the focal spot.

[8 marks]

Question 2

The heat load on an anode during an x-ray exposure is expressed in heat units (HU) as

$$f \times \text{kVp} \times \text{mA} \times (\text{exposure time in seconds}) \quad \text{HU}.$$

The factor f is 1 for single-phase, fully-rectified power and is 1.35 for three-phase, six-pulse power. Explain in three or four sentences why f is larger for three-phase, six-pulse power.

[5 marks]

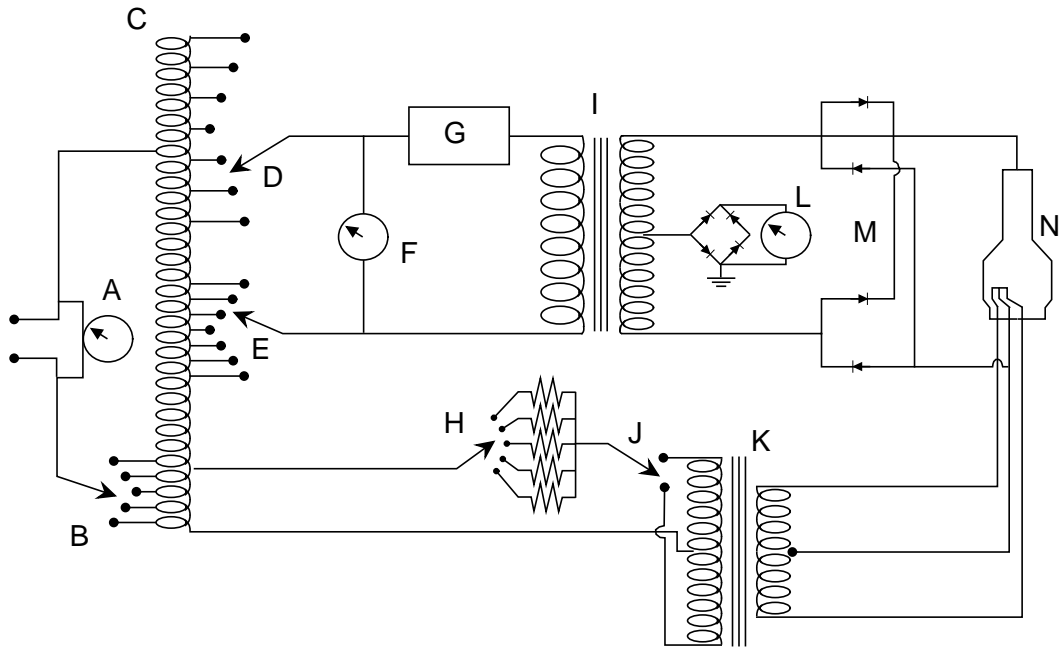

Question 3

A schematic circuit diagram for an x-ray machine is shown above, with some components labelled A-N. Which labels correspond to the

- (a) focal-spot selector,
- (b) step-up transformer,
- (c) line compensator,
- (d) mA selector, and the
- (e) major kVp selector?

[5 marks]

Question 4

The absorption of x-rays in a patient occurs via the photoelectric effect, which produces an electron and a photon. Describe this absorption process in about three sentences (perhaps with a diagram). What is the fate of the products? [5 marks]

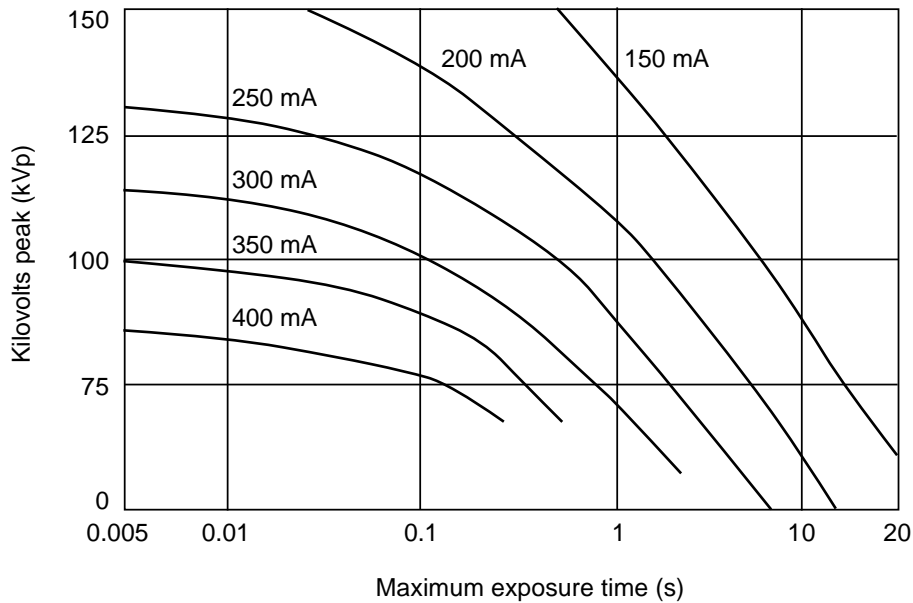

Question 5

The figure above is a radiographic rating chart for an x-ray tube. It indicates a limit to the duration of an exposure with given kVp and mA settings.

- (a) Explain in one or two sentences what is responsible for this limit.

- (b) What is the maximum exposure time for 250 mA and 100 kVp?

- (c) Why is the limit longer for smaller kVp at the same mA?

- (d) What would the maximum exposure time be for 250 mA and 75 kVp?

- (e) Will increasing the tube current while keeping the kVp fixed at 75 increase or decrease the maximum exposure time? Why?

- (f) What is the maximum exposure time for settings of 75 kVp and 400 mA?

[7 marks]

Question 6

Describe what is meant by the following terms, using one or two sentences for each one.

(a) thermionic emission

(b) K-characteristic x-ray

(c) exit radiation

(d) half-value layer

(e) radiolucent

[10 marks]

End of Part B